

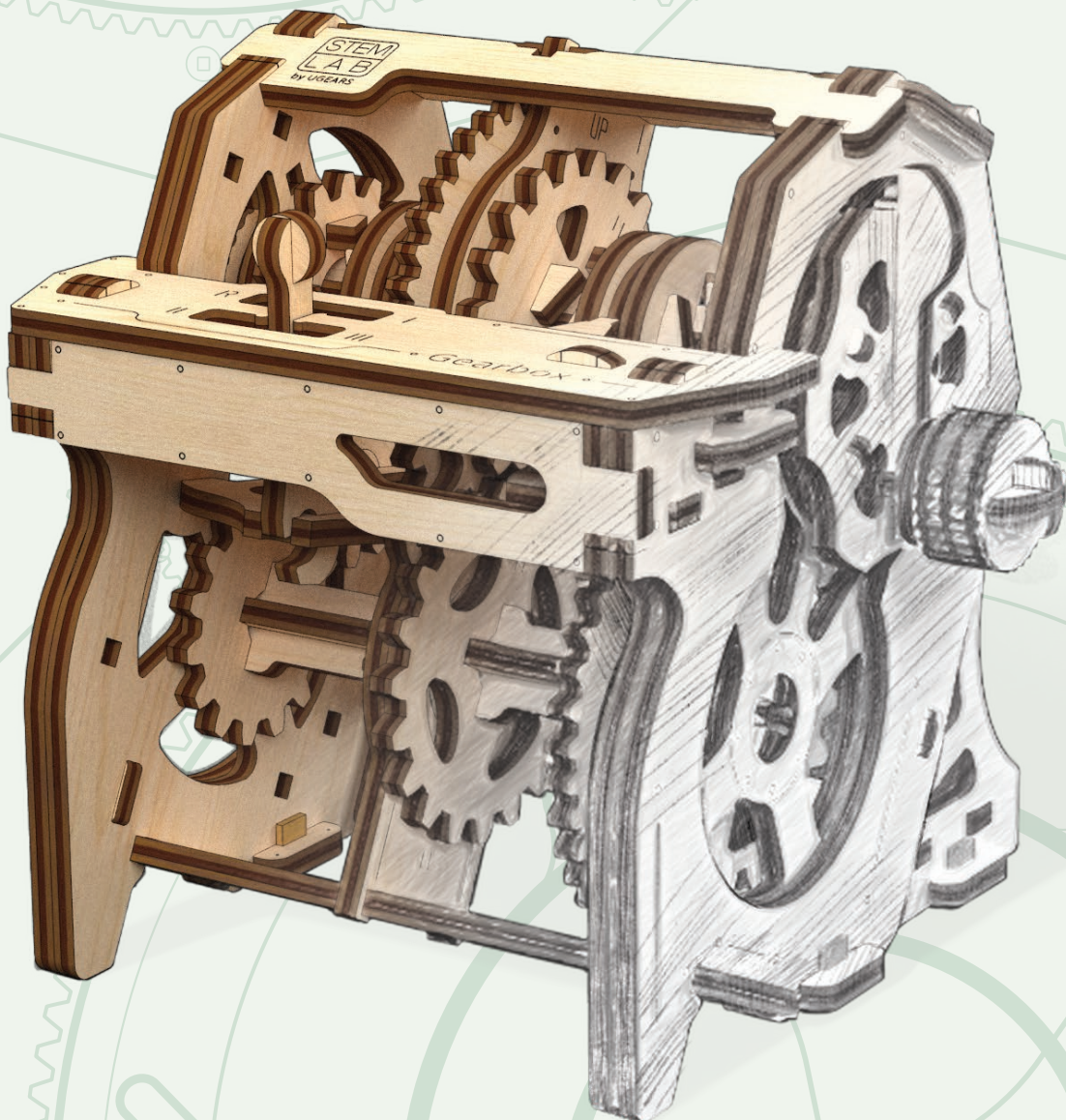

MECHANICAL MODEL

GEARBOX



Handbook of A Young Engineer

§1

Introduction

■ **An inquisitive mind always seeks new knowledge.** How fascinating it is to get to know the world – to learn why night follows the day, how a large plane stays in the air, what’s inside the human body, what are the powers that make mechanisms work? Didn’t you ever want to take apart and disassemble a device or a gadget? An old radio found in the garage, a broken mixer forgotten in a pile of old junk in the basement?

■ **Or maybe you were aiming for something really large?**

Like a car that has hundreds of parts and details. Just like molecules in a living body, the details assemble in mechanisms, mesh and connect to become a vehicle. One of the most important units comprising a mechanical body is the gearbox.

Without it, the car would only move forward and its speed would be controlled only by the power of the engine.

But wait! Do you know that it is not only the engine that regulates how fast your car goes? Do you know what makes it go slower, faster or even backwards while the engine works at a constant rate?

Welcome to the world of fascinating mechanics!

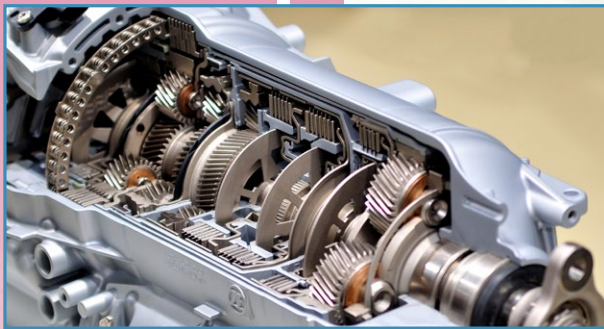
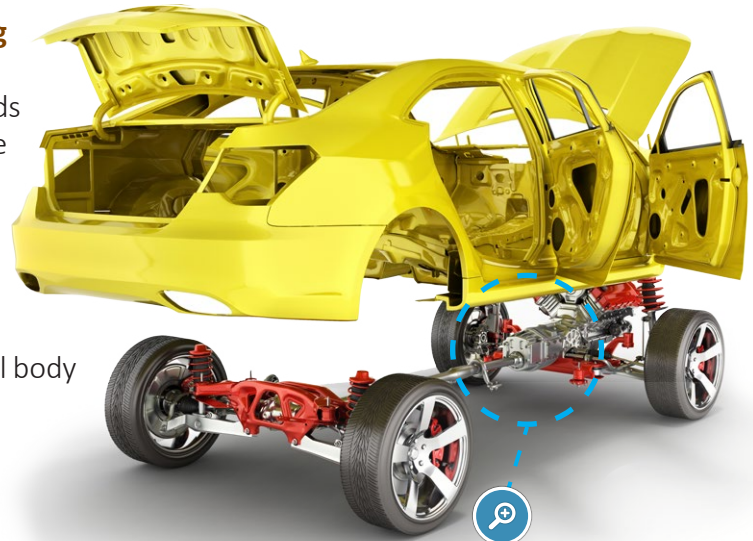

The gearbox controls balance between the speed of motion and the force required to surmount obstacles, such as going up or downhill, faster or slower driving, etc. This gives the driver the possibility to drive more comfortably and also provides driving in reverse mode.

There’s also idling... But let’s not get ahead of ourselves.

■ **The “Gearbox” from Ugears STEM-lab range that works as a real-life gearbox will help you to better understand this mechanism in detail. Assembling it with your own hands will make it very clear what a gearbox is and how it works in a car.**



Gearboxes are not exclusive to vehicles but are also in industrial machines and mechanisms, in different production lines, etc. In turning machines the gearbox is used to select the speed of the billet rotation and make sure the operator uses the right process rate.

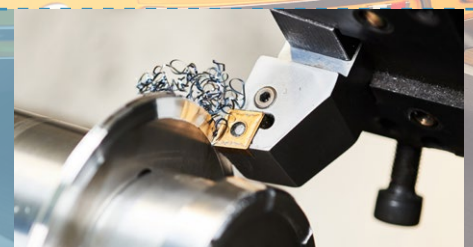

§2

Historical reference

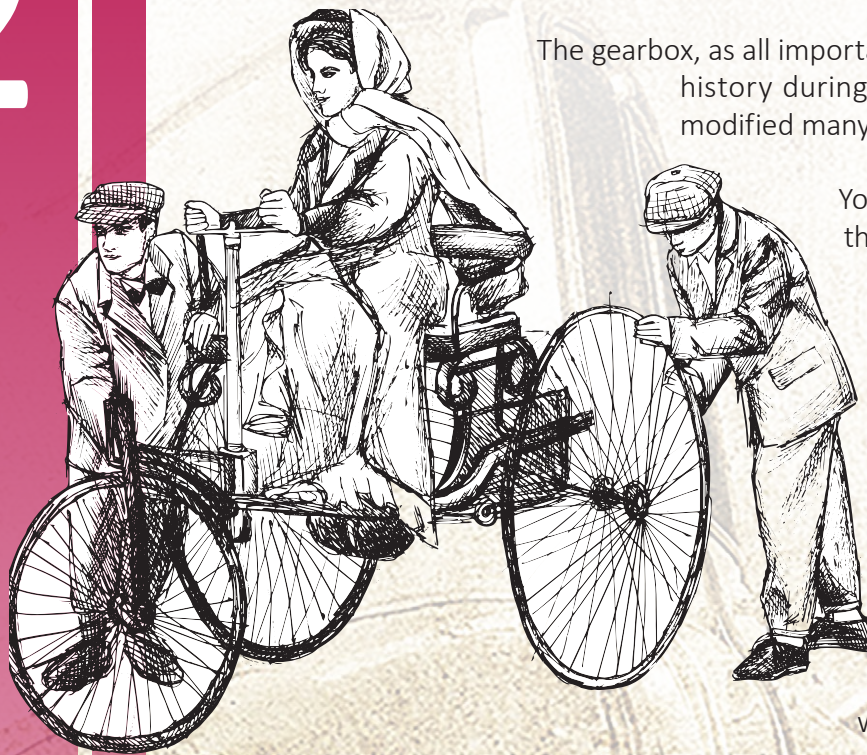

■ When, how, who invented it and for what purpose?

The gearbox, as all important inventions do, has its own history during which it was improved and modified many times.

You might be surprised to know that cars haven't always looked like the modern automobiles we use today. Every period had its own unique style reflected in the design of that time's vehicles.

When Karl Benz invented the gearbox in 1887, he installed it in a car resembling a coach or a carriage. And yet it was a proper automobile with an engine and a gearbox!

■ The credit of coming up with the idea and the original design of a gearbox belongs to Karl Friedrich Benz, famous German engine designer and automotive engineer.

There's a widely believed story that the idea of this invention came to Benz after his wife's unfortunate trip to visit her mother. In 1888, she went on an 80 kilometer ride with children and a load of luggage. Some 106 km or around 65 miles was quite a distance for automobiles of that-time, so it was no wonder that the car became very temperamental in a short while. The feeble engine of some 0.8 horse power (for comparison – modern cars have an average capacity of 150 horsepower) couldn't push the vehicle up hill and the car had to be pushed to the top of every hummock. After that exhausting journey, Benz had to come up with a solution to improve automobiles, which came in the form of a gearbox.



Karl Friedrich Michael Benz was a German engineer, and inventor of one of the first internal combustion engines. A pioneer of the automobile industry, his company eventually grew into Daimler-Benz AG.

Cäcilie Bertha Benz,

Karl Benz's wife, became the first inter-city car traveller. On August 5th, 1888 she borrowed her husband's car without letting him know and ventured on a risky trip from Mannheim to Pforzheim, along with her two older sons. On their way they made several pit-stops to buy gasoline in the drug-stores (at that time, it was sold there as a detergent)

He used a **leather belt on metal plates** with a slot (they are called “the pulley wheels”). The system looked like this:

■ The engine shaft (the shaft that provides impulse is called the **drive shaft**) had a large diameter pulley on it (**driving pulley**).

The shaft that propelled the wheel (the shaft that receives the impulse is called The belt on the first driven pulley) had two different diameter pulleys (**driven pulley 1 и 2**).

With a special lever (that today we call a gear shift lever, or just shifter) the driver could shift the belt from one driven pulley to another without engaging the driving pulley transmitting the steady torque from the engine.

This is how the gearbox was invented!

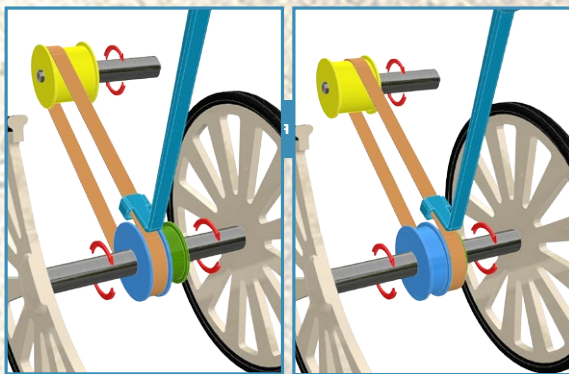

The belt on the first driven pulley. Position 1: slower driving, but stronger power.



The belt on the second driven pulley. Position 2: the car goes faster

Since driven pulleys had different diameters, the rotation speed changed. This is the overall ratio. The **over-all ratio** is the foundation of a gearbox and the whole idea of a transmission system.

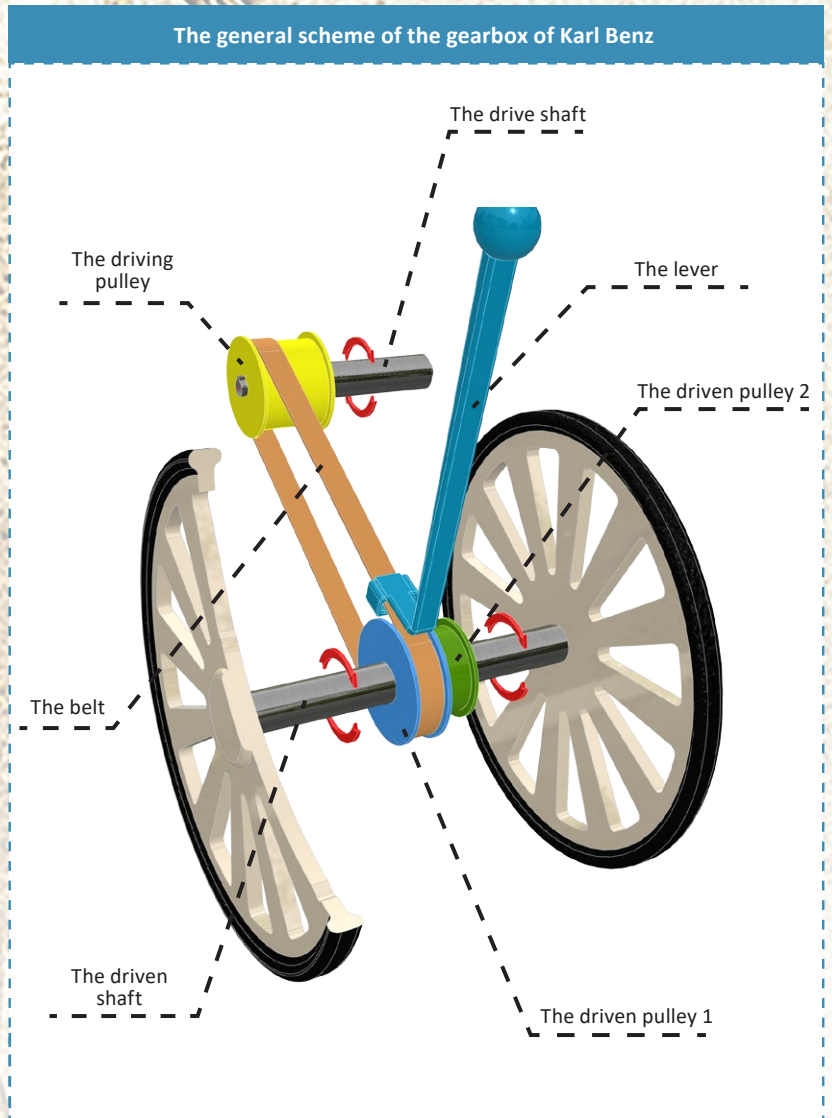

■ **Fun fact!**

The driven pulley was not simple metal detail, but a mechanism comprising the pulley itself and a differential. Find out about the main principles of the differential’s working with Ugears “Differential” 3-D puzzle from the STEM collection. This model is a fully functioning replica of a real-life differential.



Years passed and technology evolved. These days, no one uses the original Karl Benz design gearbox. The belt has been replaced with a chain with gears instead of pulleys, and some other minor general tweaks, you get a mechanism that is still widely used in bicycles.



1 Scan QR to download App



2 Open the application



3 Point and align the image on the screen with the model

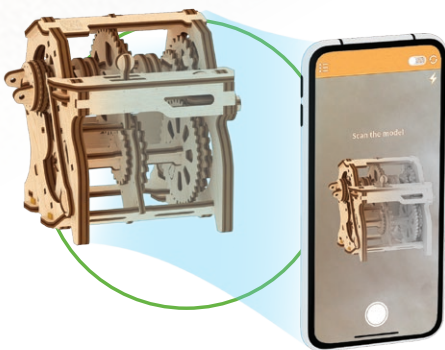

4 Interact in AR



Each of the mechanical models of the UGEARS STEM-lab series is an interactive study guide to a mechanism.

Assembling the GEARBOX with your own hands you will get a full, in-depth understanding of the principles of how it works.

Extend your learning experience even further with the Ugears augmented reality application. Point your tablet or smartphone at a fully assembled STEM-lab model and the app will show you real life usage of the mechanism you've just built.

You will see how the GEARBOX works in a car; explore it at different angles, zoom it in and out.



Enjoy our unlimited support!

Should you have any questions about assembly, we are always here for you to suggest the best solution and provide the help you might need. Our 24/7 customer support service will accept and process your request promptly and professionally.

Customer support:
customerservice@ugearsmodels.com

§3

LET'S TAKE A CLOSER LOOK AT THE MODERN MECHANICAL GEARBOX AND FIND OUT HOW IT IS DIFFERENT FROM AN AUTOMATIC TRANSMISSION.

About the Mechanism and the Range of its use

The gearbox is a part of an automobile transmission (1). Its main purpose is to receive, convert and transmit torque from the engine to the wheels. Long story short – it controls the rotation speed of the wheels while the engine is turning at the same revolution.

Fun fact! There is a common widely recognized graphical symbol used to identify modes in both mechanical and automatic transmissions. It is an image of a shifter and its modes.



Mechanical



Automatic

Gearbox input shaft

The input or drive shaft is the primary receiver of torque produced by the engine when the clutch (2) is engaged.

Countershaft

The countershaft (also called Jackshaft) is a mechanical component between the gearbox drive and driven shaft.

Reverse gear unit

Note that there are 3 gears unlike a pair of gears in the others. The third gear moves the driven shaft in reverse initiating the reverse movement of the vehicle. This is a reverse gear.

Reverse gear

Gearbox driven shaft

Transmits the torque to the drive wheels when one of the gears engaged

Shifter shaft

The Shifter shaft is connected with a shaft fork. Because of that there is the same number of these details. The driver uses the shifter, which selects which shifter shaft will engage to switch the gear.

The transmission selection lever (AKA the shifter).

It's one of the most familiar details of the mechanism that sits in plain view right next to the driver.

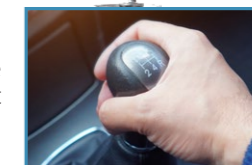

Transmission shaft fork

The detail controlling moving and meshing of the gears when switching the transmission modes.

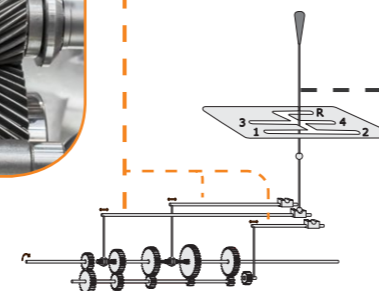
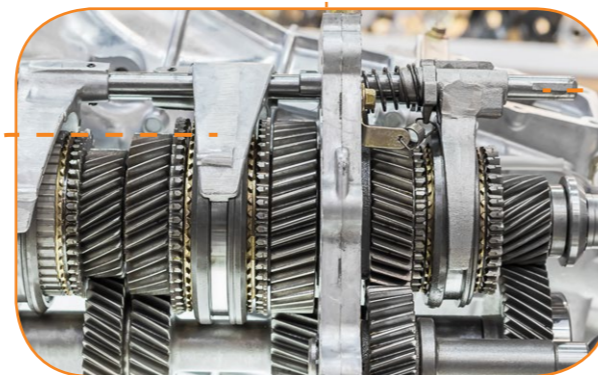

¹ Transmission – it is a complex of mechanical blocks and mechanisms connecting the drive wheels of a vehicle or a driving mechanism of an industrial machine, also engaging the rest of the systems ensuring the functioning of the system. You can see some elements of a transmission in the diagrams: 1 – gearbox, 2 – drive shaft, 3 – differential, and 4 – rear axles.

² Clutch is the mechanism that works due to rolling resistance. The clutch controls the connection between the shafts, smooth switching between gears and disengages the transmission from the engine.

Some cars use automatic transmission

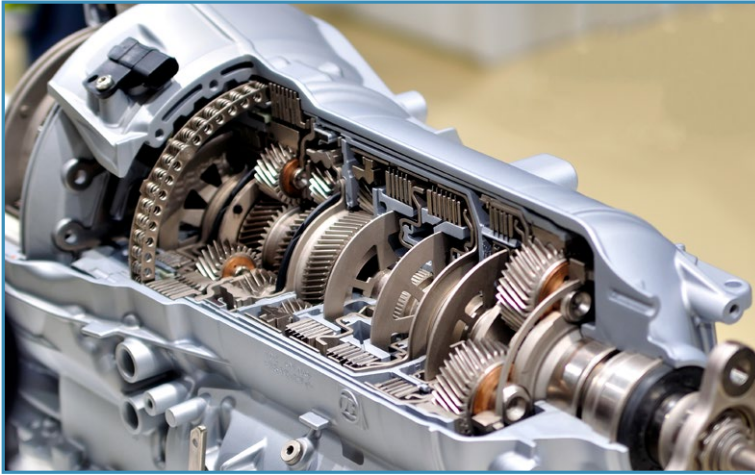

Automatic transmission planetary gear box

The main difference between mechanical and automatic transmission is that the latter one shifts gears automatically.

The automatic transmission has many advantages compared to the mechanical one, such as high reliability with proper use. Controlled by a computer the automatic transmission chooses the best time to shift from one gear to another ensuring safe and smooth transition.

This guarantees longer engine life. It also prevents the car from rolling downhill if you let go of the break pedal on a slope and facilitates starting when going uphill. But frankly speaking,

in many cases drivers choose automatic due to reluctance and lack of skill when it comes to shifting the gears manually, while this fail-safe mechanism does it like a professional.

But of course, there is always a downside, which in the case of an automatic transmission is the need of regular service and an expensive repair in case of malfunctioning or breaking.

Automatic transmissions can be **planetary, continuously variable, and automatic manual.**

Today, the automatic transmission is the most popular, if you look at the global statistics of car sales. At the same time, the mechanical transmission is also used widely and considered more reliable. The most common gearbox has six gears – five speeds and reverse.



§4

Physics and Mechanics explained in “Gearbox” STEM-model

■ So how does the gearbox change a car’s speed?

The engine drives the input shaft of the transmission; then the motion is transmitted to the gears; the gears begin to rotate with a different speed; the driver moves the shifter to the first gear (also known as a low gear).

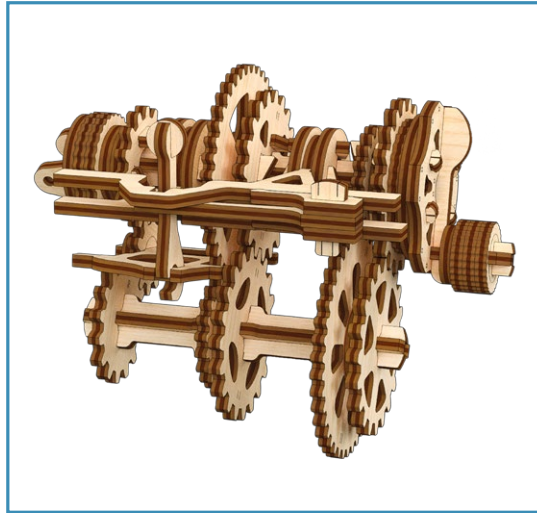

Shifting the lever, the driver engages the fork that is a part of a mechanism transmitting the torque from the gears to the driven shaft. This mechanism is called “a synchronizer”. When the synchronizer meshes with a gear arrangement of a selected speed mode the driven shaft starts to rotate transmitting torque to the crankshaft and further to the differential. The differential distributes the torque between drive wheels and the car shifts to the selected speed mode. The “Gearbox” STEM model works exactly the same way.

Now when we know how the gearbox works, let us look at the main terms and definitions.

When describing the mechanism of the gearbox we use terms from physics, mechanics, and automobile construction. This is what we are going to talk about, starting with a basic term from physics – Force. The term was introduced by Isaac Newton.

A newton (F) is a unit of force. A physical value that determines how one object effects the other. For example, we often say how strong we are, but what we really mean is how much we can effect other objects. The Force is measured in Newtons.

A lever is a rigid rod pivoted at a fulcrum. An example of a lever is a wrench. When we want to unscrew a nut, we fix one end of our wrench on it while pulling the other end – making a lever out of it.

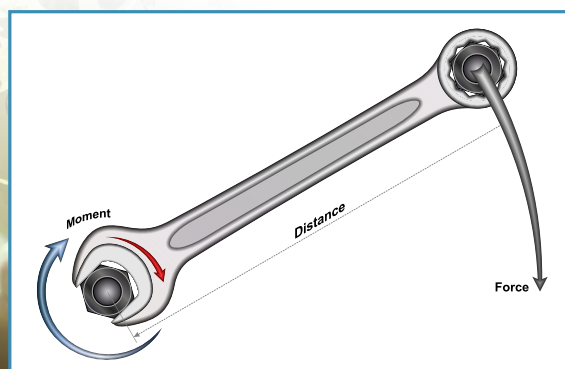

Sir Isaac Newton

Was an English physicist, mathematician, engineer, and astronomer, one of the founders of classical physics. The author of Mathematical Principles of Natural Philosophy describing the law of universal gravitation, and three laws of mechanics that became the grounds for classical mechanics.

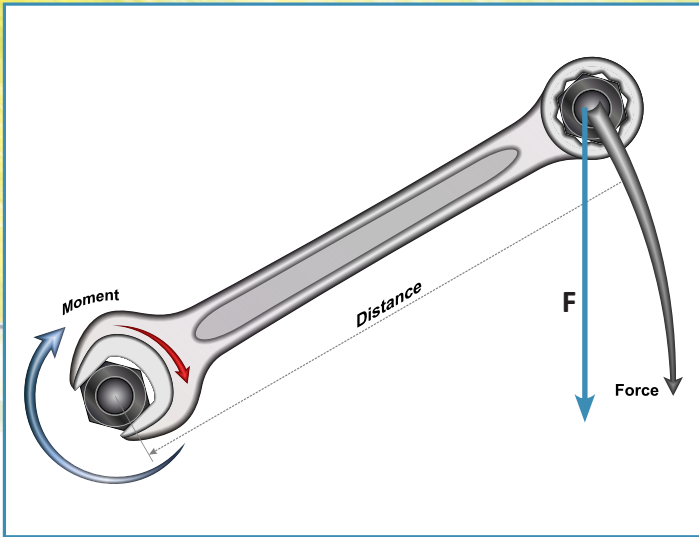

Torque (moment of force) is a product of force and a lever arm. As you must remember, force is measured in Newtons. The lever arm is measured in meters or feet (like the length of the wrench). Which gives us a following formula of the moment of force: $1N * 1m = 1Nm$. $1Nm$ equals is a force of $1 N$ applied to a lever arm of $1 m$.

In internal combustion engines, force comes from the fuel that ignites in the cylinder then to the crankshaft assembly, and to the crank shaft. The crank shaft engaging with the transmission system rotates the wheels.

Torque is not a constant. It will increase with a stronger force applied to the lever arm and vice versa. If the driver pushed the acceleration pedal, the force applied to the lever grows as well as the moment of force.

Everybody knows that it is easier to open a door pulling or pushing it as far from the hinges as you can. This is why the handles are placed where they are. The closer to the hinge we push the door the greater chance we have to stay inside. This is where we have to deal with the arm of force.

Transmission – the gear train that controls torque coming from the engine to the driving wheels.

Reduction factor or reduction ratio is the ratio between the number of cogs of the driven and drive gears.

Reduction ratio is one of the main characteristics of a gear transmission that transmits torque from the engine to any other unit or device.

Power.

Torque is directly connected to the power of the engine. In simple words, power is work done by the engine within a period of time. Since the torque is in fact the work the engine does, the power represents how many times the engine produces torque in a certain period of time.

Physicists invented a formula that connects torque to power. P (power) = torque * N (the number of revolutions the engine makes per minute) / 9549 (correction factor).

Power is measured in kilowatts. However, this was adopted as horsepower among the general public.

In order to convert kilowatts to horsepower, the number of kilowatts are multiplied by 1.36

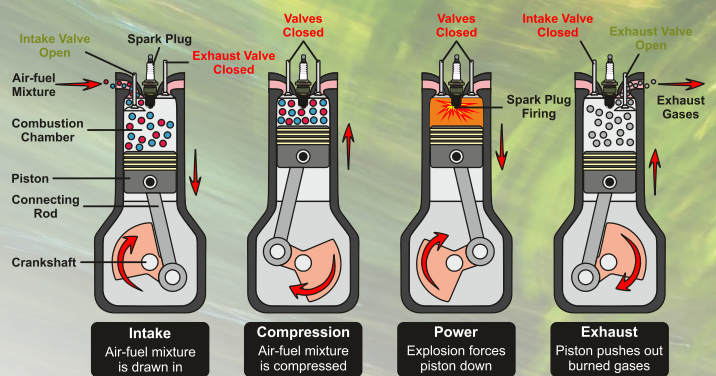

Main processes taking place in an engine

1. Fuel supply to compression chambers
2. Compression of fuel to attain required density
3. Combustion of fuel (in cars that use petroleum, the fuel is ignited by a spark plug, in diesel ones – due to the high temperature in the process of compression). Combustion is what determines the power of an engine.
4. Engine exhaust after combustion.

And then everything starts over...

Rotation rate of the driven gear: knowing the reduction factor and the rate of rotation of the drive gear, is easy to calculate the rotation rate of the driven wheel. The rotation rate is measured in revolutions per minute (rpm). Given that S_1, T_1 is a rotation rate and a number of cogs of the drive wheel.

Using the equation $S_1 \times T_1 = S_2 \times T_2$ we find that $S_2 = (S_1 \times T_1) / T_2$



§5

Technical design
and principle
of working

HERE WE ARE AT THE FINISH LINE!
LET'S SEE WHAT OUR GEARBOX IS MADE OF.

Let's check is everything is in the right place!

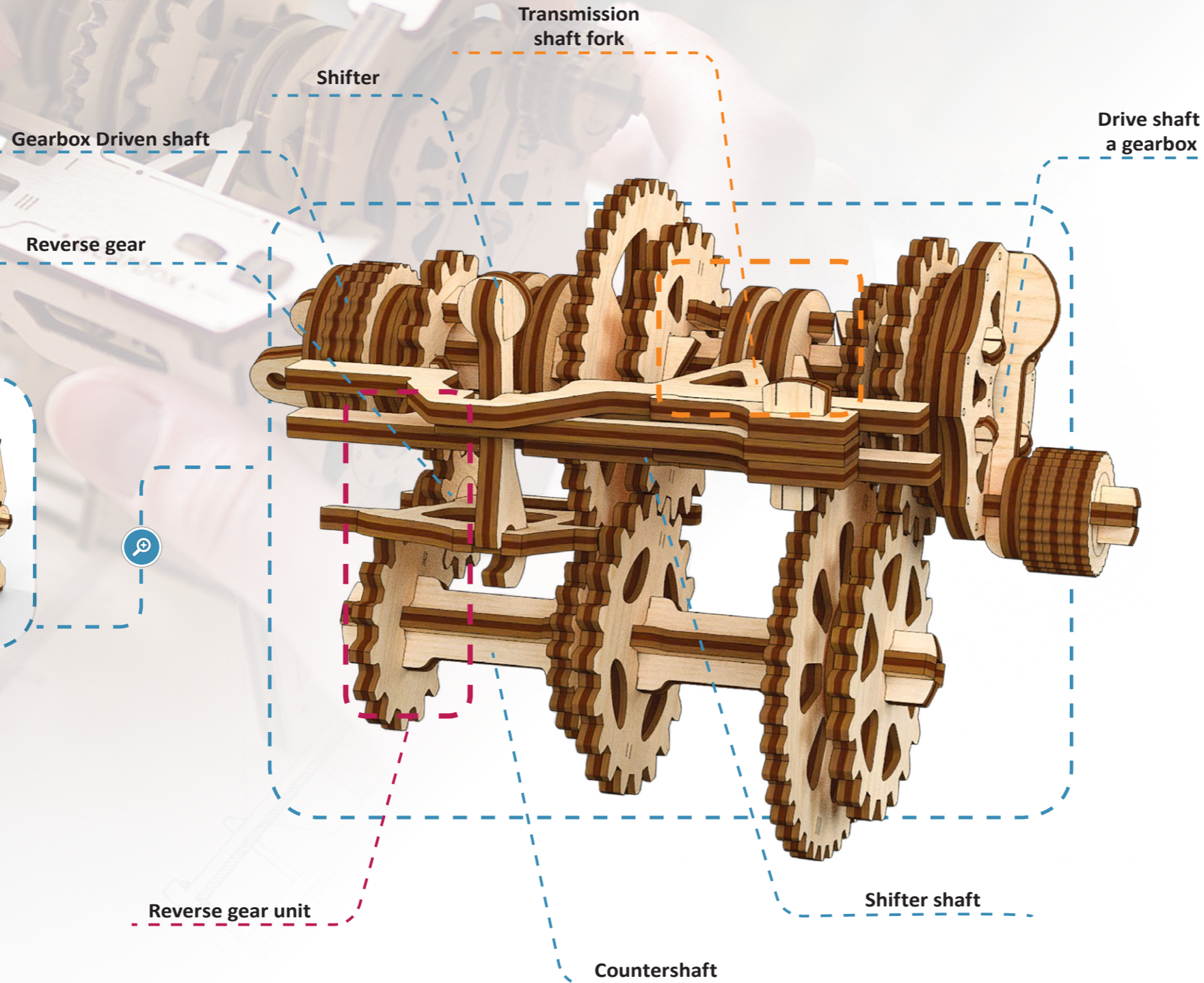
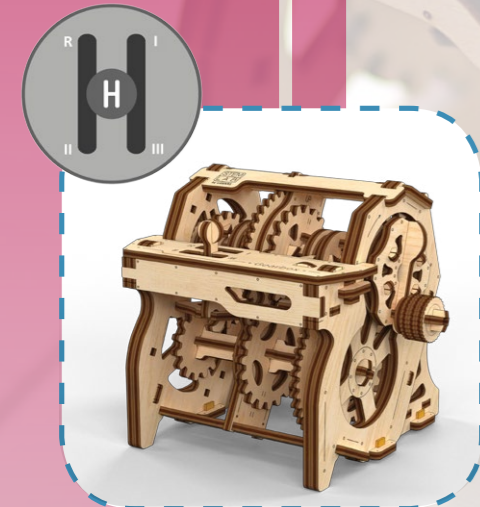

The construction kit has 120 details.
You will have no problem putting them
together using the detailed illustrated
instruction manual.



All checks out? All in its place,
which means – it's time to get to work!



§6

Formative hands-on tasks

Measuring driving and driven gears reduction ratio; calculating the rotation frequency (rate).

Objectives: to study the ways of measuring the gearbox's reduction ratio. Find the connection between the rotation frequency and the position of the lever. Develop logic, science skills, and spatial thinking.

Equipment: the Gearbox, a stop-watch, ruler, notepad and pen.

Theoretical background of the experiment:

Gears are the wheels with meshing cogs. In this way the gears translate movement and energy very efficiently. A driving gear is set in motion by an external force – such as your hand, for example. Any gear meshing with the driving gear is known as a driven gear. The driving gear translates input force and the driven one – output force. Using an arrangement of gears, one can control the speed, the direction, and the output power.

Preparation for the experiment:

1. Assemble the Gearbox and set it on a flat surface.
2. Set the lever in the “idle” position.

WORK PROGRESS:

Task 1

Sketch up a scheme of a gearbox on a sheet of paper. Use your illustration to explain how the gearbox works. This is about what you would improve in the mechanism as an engineer and inventor.

Task 2

Think about what objects in your house the gearbox resembles.

Task 3

Multiple choice assessment:
Choose all that apply

1. What is a gearbox made of?

- a) shafts
- b) gears
- c) lever

2. Which part of the gearbox is a part of a car's interior?

- a) Shafts with gears
- b) Axles
- c) Transmission selection lever

3. The gearbox is part of what car mechanism?

- a) transmission
- b) engine
- c) steering column

4. What is the gearbox used for?

- a) To put on the brake
- b) To change speed
- c) To move in reverse

5. What kind of gearbox is the most common?

- a) Two gears – two speeds and reverse.
- b) Six gears – five speeds and reverse.
- c) Ten gears – five speeds and five reverse speeds

MECHANICAL AND PHYSICAL PHENOMENA YOU CAN LEARN ABOUT FROM THE MODEL

The gearbox provides control over the amount of force (torque) transferred to the driving wheels, puts the engine and transmission in idling mode when stopping, as well as to move in reverse.

The gearbox is a device in which the gears can mesh in different combinations changing the reduction ratio. Its functioning is based on the following physical phenomena: work (A), force (N), and speed (v).

Work is the product of force and displacement.

$$A = F \cdot l$$

Si unit of work, a joule (J), was named after the English physicist James Prescott Joule.

In order to do the same work different engines need different time. The work done per unit of time is characterized by power.

Power is a very important characteristic of every engine.

For a vehicle it is easier to calculate it using speed and force rather than work and time. The force is applied to an object and ensures its constant movement. Speed is the distance the object travelled per unit of time. Taking this into account we can write it as the following formula:

$$N = \frac{F \cdot l}{t} = F \frac{l}{t} = Fv$$

From this formula we can see that power is force multiplied by speed.

While moving with constant speed, the force of the engine compensates for the travel resistance.

The formula explains why a driver wants to switch to lower gear when going uphill: in order to increase the force while having the engine producing the same amount of power, the speed has to go down.

ASSESSMENT TASK

1. The gearbox serves to...

- a) change torque
- b) switch on turning signals
- c) allow the car to move in reverse

2. What are the functions of the gearbox?

- a) To control the amount of torque
- b) To control the direction of torque
- c) To increase the power

3. Which of the listed shafts are not the part of the gearbox:

- a) driving shaft
- b) driven shaft
- c) propeller shaft

4. How do the speed of the car and the torque supplied to the driving wheels change if the reduction ratio increases?

- a) the speed reduces, the torque grows
- b) the speed grows, the torque grows too
- c) the speed grows, the torque reduces

5. The credit of invention of the gearbox belongs to a famous German engineer...

- a) Rudolf Diesel
- b) Nikola Tesla
- c) Karl Benz

6. The gearbox is a part of a car's...

- a) body
- b) engine
- c) Transmission

7. The main part of the gearbox is found under the car and is made of:

- a) the shift lever
- b) the axles
- c) shafts, gears, and axles.

8. What types of gearboxes are used in automobiles?

- a) electric
- b) hydraulic
- c) mechanic.

9. How does the torque change if the speed increases?

- a) increases
- b) remains the same
- c) decreases.

10. What does the reduction ratio indicate?

- a) the number of cogs in a gear
- b) torque
- c) the ratio between the driven and drive gears.

Congratulations! You made it!

Thank you for being with us in this adventure, we hope you had fun and learned a thing or two!